

Saves up to
58 %
energy¹



Product features

- Attractive and functional product design
- LEDs with opal cover for homogeneous illumination and minimised glare
- Lay-in mounting
- Simple, quick installation due to integrated ECG

¹Compared to a luminaire with conventional technology: Presumable ballast losses with traditional solution are taken into account in expected energy savings.

Light is durable

LIGHT PANEL LED

LED lay-in luminaires with uniform luminous surface.

Light is OSRAM

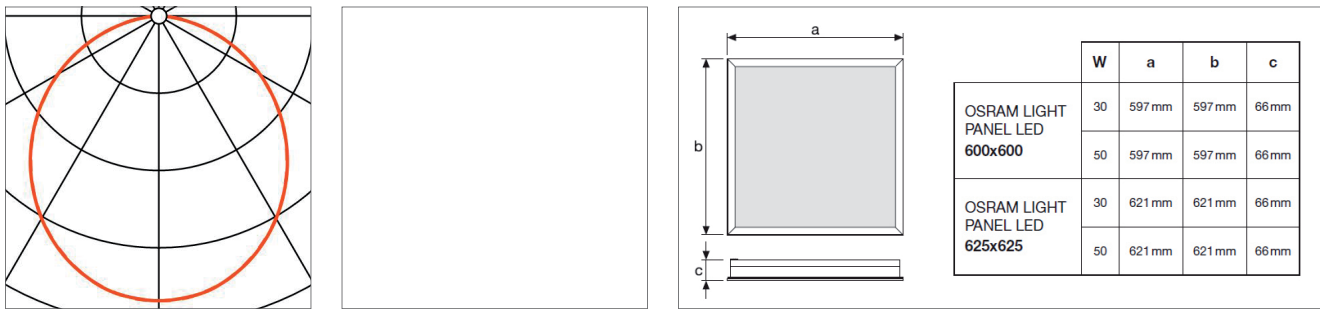

LIGHT PANEL LED

Service life up to 30.000h (L80/B50 @ T_a = 25° C)

Type	K	R _a	lm	W	Order No. OSRAM	Order No. Siteco
LIGHT PANEL LED 2800lm 600 x 600	4000	> 83	2800	30	4052899945999	0LF12A7L32840
LIGHT PANEL LED 2800lm 625 x 625	4000	> 83	2800	30	4052899945906	0LF11A7L32840
LIGHT PANEL LED 4200lm 600 x 600	4000	> 83	4200	50	4052899945913	0LF12A7L49840
LIGHT PANEL LED 4200lm 625 x 625	4000	> 83	4200	50	4052899945920	0LF11A7L49840

– Energy efficiency class contained LED modules A++, A+, A. LED modules cannot be replaced

Economic, durable and simply replaceable

Homogeneous light – from any angle

LIGHT PANEL LED as a long-life replacement for traditional louvre solutions is ideal for most general lighting applications in commercial buildings with strip ceilings. With uniform distribution of light without dark spots, the luminaire ensures pleasant illumination and optimum colour rendering.

Applications

- General lighting in the following areas:
- Foyers, lobbies and reception areas
 - Conference rooms
 - Corridors, stairways and ancillary rooms (recreation rooms/archives)

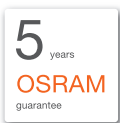

www.osram.com/professional-guarantee

OSRAM GmbH
 Marcel-Breuer-Strasse 6
 80807 Munich | Germany
 Phone +49 89 6213-0
www.osram.com
www.siteco.com

Customer-Service-Center OSRAM
 Phone +49 89 6213-6000

Customer-Service-Center Siteco
 Phone +49 8669 33-844
technicalsupport@siteco.de

